

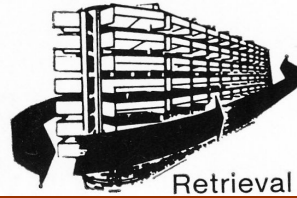

### CAROUSEL



### CONTAINS QUIZ TO DETERMINE EFFICIENCY OF A DISTRIBUTION CENTER

BASED ON INSTALLED DIRECT LABOR CONTROL SYSTEMS, STORAGE RACK TYPES, LEVEL OF ROBOTICS, LAYOUT METHODOLOGY, DEGREE OF INVENTORY / TRACKING SOFTWARE AND MATERIALS HANDLING MECHANIZATION

## NEW BOOK

### “CLASSIC PRODUCTIVITY SYSTEMS

*for the assembly manufacturer or distribution center”*

A collection of labor and space optimization techniques, conveyor types, case histories, materials handling layout configurations & sizing dials and examples of various ROI scenarios designed to assist the industrial sector be cost competitive.

There are two versions of the book: Rev A (316 pages) will contain JD Gray Associates’ generic industrial engineering proposals should your company seek outside expertise in your cost reduction endeavors. Rev B (279 pages) will not.

\$75 with a 30-day delivery! Includes sales tax, shipping and handling. Send check or money order to PO Box 63 Summit Hill, PA 18250 USA.

CONTAINS ILLUSTRATIONS AND ROI'S FOR VARIOUS PICK AND PACK ALTERNATIVES USING PACED PACKAGING WITH LIVE STORAGE AND RETRIEVAL (MANUAL, LIGHTTREE, ROBOTIC) CAROUSELS !

#### ROBOTIC PICK

#### MANUAL PACK

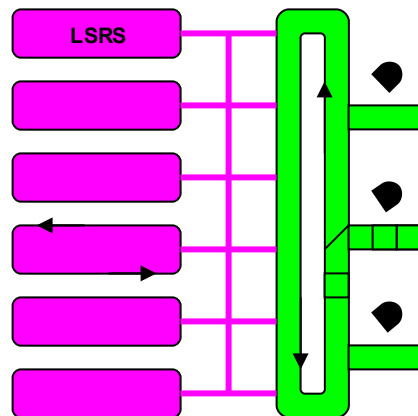

CONTAINS EXAMPLES OF PACED ASSEMBLY SCENARIOS, INDUSTRIAL ENGINEERED STANDARDS AND INDUSTRIAL INCENTIVES SUCH AS GROUP PIECE WORK & GAIN SHARING INCENTIVES!

CONTAINS STEP-BY-STEP PROCEDURE ON HOW TO PREPARE YOUR OWN DISTRIBUTION CENTER AUDIT!