

**JD GRAY ASSOCIATES
MANUFACTURING PRODUCTIVITY CONSULTANTS**

**CAN'T AFFORD TO AUTOMATE?
SEMI-AUTOMATE!**

BASIC EXPANDABLE MODULE – 24” SQ PALLETS

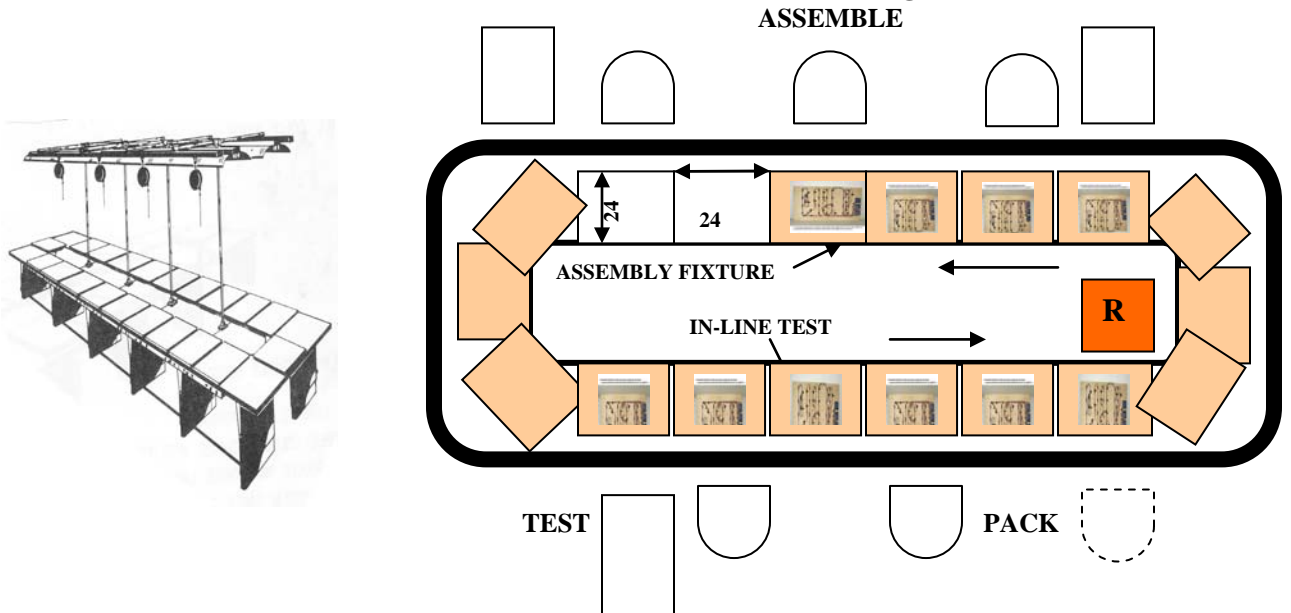

PRECISION INDEXING ASSEMBLY CONVEYOR W/ WORK CELL ROBOTICS

Standard Rotary Assembly Conveyor Model 2424, 22' 6" OL, 18 pallets, 6 pallets/side (3 pallets on each end), Variable Dwell time, 3 operator/side with 4 supports.....\$34,139

Quotation No: 1804

Standard Rotary Options. Variable speed indexing, fluorescent lighting fixtures, electrical outlets beneath pallet for six operators, upper supports to support lighting fixtures, pneumatic quick disconnect with air piping for six operators, tool tray railing, overhead rail with trolleys for six operators.....\$10,201

Quotation No: 1805

Standard Rotary Precision Pallet Locating System for One Work Cell. 1 shot pin locating device and 18 pallet shot pin blocks..... \$8,815

Quotation No: 1806

Terms: Letter of Credit from central bank in customers region. 50% down payment upon purchase order assignment and tour of manufacturer's facility. 50% final payment upon inspection and test run of assembly conveyor at manufacturer's facility. Shipping: Customers responsibility from manufacturer's New York facility location. Delivery: 90 days

**JD GRAY ASSOCIATES
MANUFACTURING PRODUCTIVITY CONSULTANTS**

DELUXE ASSEMBLY CONVEYOR WITH ALL STANDARD OPTIONS

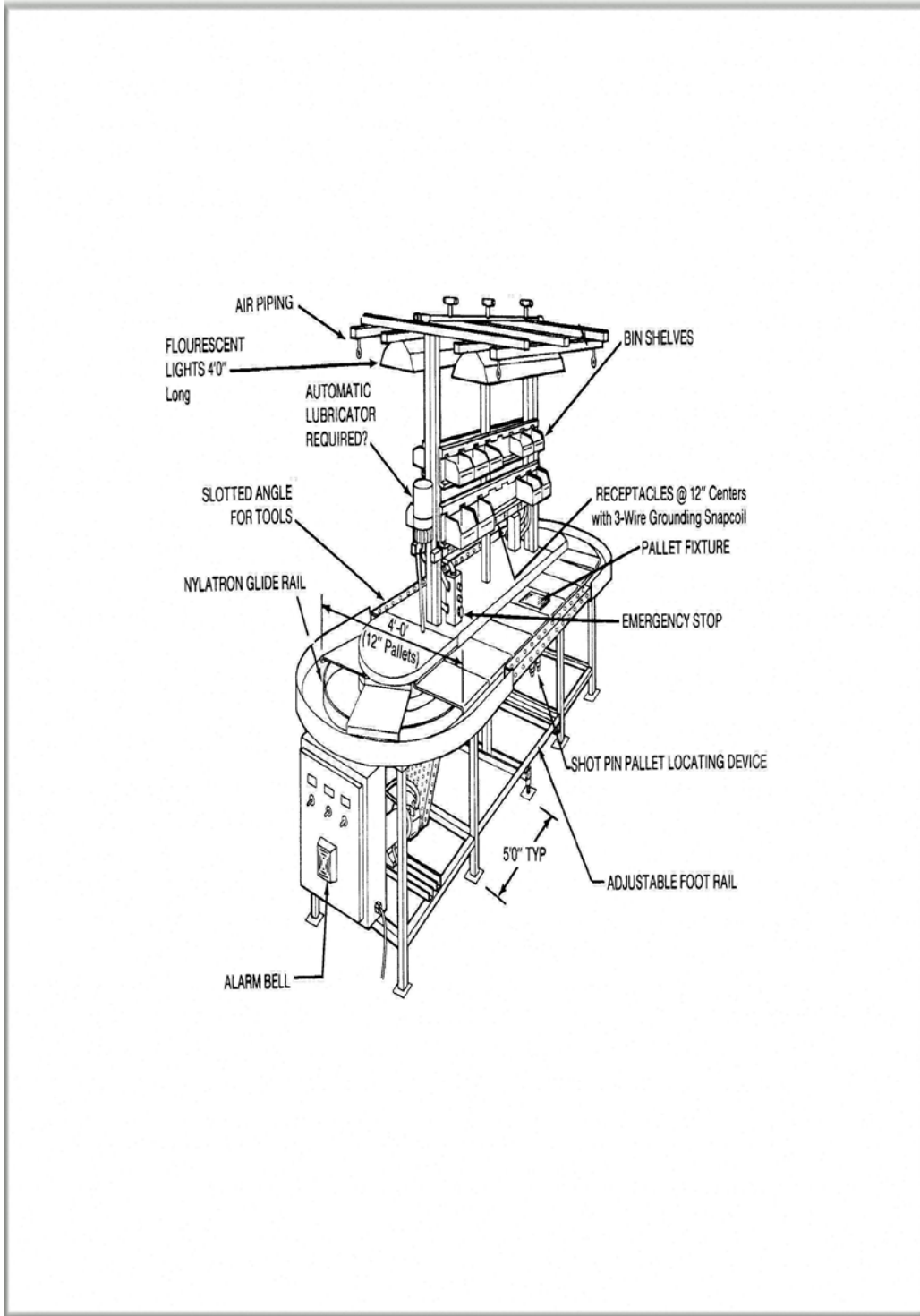

**JD GRAY ASSOCIATES
MANUFACTURING PRODUCTIVITY CONSULTANTS**

EQUIPMENT WARRANTY

Our New York manufacturer warrants to the original purchaser that all materials and equipment furnished will be new unless otherwise specified and approved by purchaser.

Our New York manufacturer further agrees to furnish the purchaser without charge, F.O.B. NY any part proved to be defective within one year from date of shipment, provided the purchaser gives JD Gray Associates immediate notice in writing and examination proves the claim that such materials or parts were defective when furnished. Our New York manufacturer will not repair or replace any parts that become inoperative because of improper maintenance, overloading, chemical or abrasive action, excessive heat, or other abuse.

Equipment and accessories not fabricated by our New York manufacturer are warranted by their original manufacturer.

Equipment that has been altered or modified by anyone without our New York manufacturer authorization is not warranted.

Unless otherwise agreed in writing by our New York manufacturer, purchaser shall bear the expense of the installation. The liability of our New York manufacturer shall be limited to furnishing such part or parts found to be defective.

Other than the above, there are no warranties which extend beyond the description of the face hereof. Consequential damages of any sort are wholly excluded.

Basic Unit

MOTOR – ¾ HP, AC motor with variable speed control (customer to specify voltage upon order)

CONTROLS – Variable Frequency drive with potentiometer and knob for speed control. Start stop buttons and Emergency stop switch.

SUPPORTS – Adjustable 35” to 36 ½” to top of pallet, with pipe foot rail on both sides.

WHEEL RAIL – Wheels 1 15/16” diameter, zinc coated, on 3” centers.

FINISH – Industrial Enamel (Customer to specify color)